



DECLARATION OF PERFORMANCE



DoP: 0038

for fischer-Zykon-panel anchor FZP II (Fastener for the rear fixing of façade panels made of selected natural stones according to EN 1469) – EN

1. Unique identification code of the product-type: **DoP: 0038**
2. Intended use/es: **Fastener for the rear fixing of façade panels made of selected natural stones according to EN 1469, see appendix, especially Annexes B 1 to B 7**
3. Manufacturer: **fischerwerke GmbH & Co. KG, Klaus-Fischer-Straße 1, 72178 Waldachtal, Germany**
4. Authorised representative: --
5. System/s of AVCP: **2+**
6. European Assessment Document: **EAD 330030-00-0601**

European Technical Assessment: **ETA-11/0145; 2018-07-01**

Technical Assessment Body: **DIBt**

Notified body/ies: **1343 – MPA Darmstadt**

7. Declared performance/s:

Mechanical resistance and stability (BWR 1)

- **Characteristic resistance for tension and shear loads: See appendix, especially Annex C 1**
- **Edge distances and spacing: See appendix, especially Annexes B 3 and C 1**
- **Durability: Corrosion Resistance Class (CRC) III according to EN 1993-1-4:2015**

Safety in case of fire (BWR 2)

- **Reaction to fire: Anchorages satisfy requirements for Class A 1**

8. Appropriate Technical Documentation and/or Specific Technical Documentation: ---

The performance of the product identified above is in conformity with the set of declared performance/s. This declaration of performance is issued, in accordance with Regulation (EU) No 305/2011, under the sole responsibility of the manufacturer identified above.

Signed for and on behalf of the manufacturer by:

Thilo Pregartner, Dr.-Ing.

Wolfgang Hengesbach, Dipl.-Ing., Dipl.-Wirtsch.-Ing.

Tumlingen, 2018-12-12

- This DoP has been prepared in different languages. In case there is a dispute on the interpretation the english version shall always prevail.
- The Appendix includes voluntary and complementary information in English language exceeding the (language-neutrally specified) legal requirements.

Specific Part

1 Technical description of the product

The fischer-Zykon-panel anchor FZP II is a special anchor of sizes M 6, M 8 and M 10 which consists of a cone bolt (with external thread or internal thread), an expansion part, a sleeve and, if need be, a nut. Cone bolt and expansion part are made of stainless steel. The sleeve is made of stainless steel or carbon. The nut is made of stainless steel or aluminium. The anchor is put into an undercut drill hole and by driving-in of the sleeve it is placed form-fit.

The product description is given in Annex A.

2 Specification of the intended use in accordance with the applicable European Assessment Document

The performances given in Section 3 are only valid if the anchor is used in compliance with the specifications and conditions given in Annex B.

The verifications and assessment methods on which this European Technical Assessment is based lead to the assumption of a working life of the anchors of at least 50 years. The indications given on the working life cannot be interpreted as a guarantee given by the producer, but are to be regarded only as a means for choosing the right products in relation to the expected economically reasonable working life of the works.

3 Performance of the product and references to the methods used for its assessment

3.1 Mechanical resistance and stability (BWR 1)

Essential characteristic	Performance
Characteristic resistance for tension and shear loads	See Annex C 1
Anchor distances and spacing	See Annex B 3 and Annex C 1
Durability	Corrosion Resistance Class (CRC) III in accordance with EN 1993-1-4:2015

3.2 Safety in case of fire (BWR 2)

Essential characteristic	Performance
Reaction to fire	Class A1
Resistance to fire	No performance assessed

4 Assessment and verification of constancy of performance (AVCP) system applied, with reference to its legal base

In accordance with EAD No. 330030-00-0601 the applicable European legal act is: [97/161/EG].
The system to be applied is: 2+

Mounting condition

Figure A1:

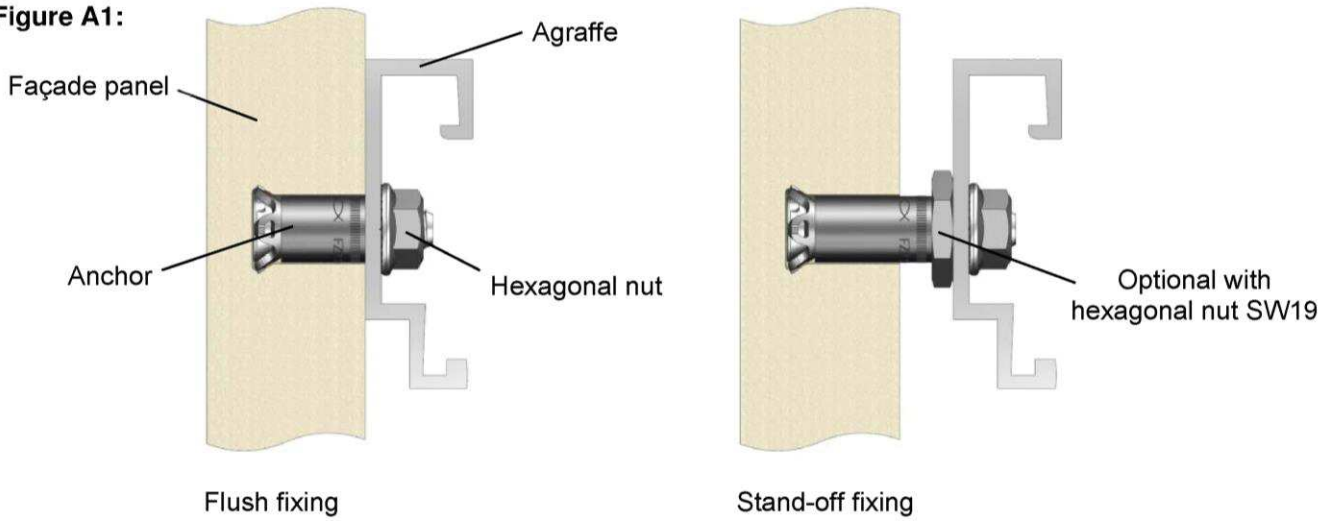

Example of façade panel on substructure

Figure A2:

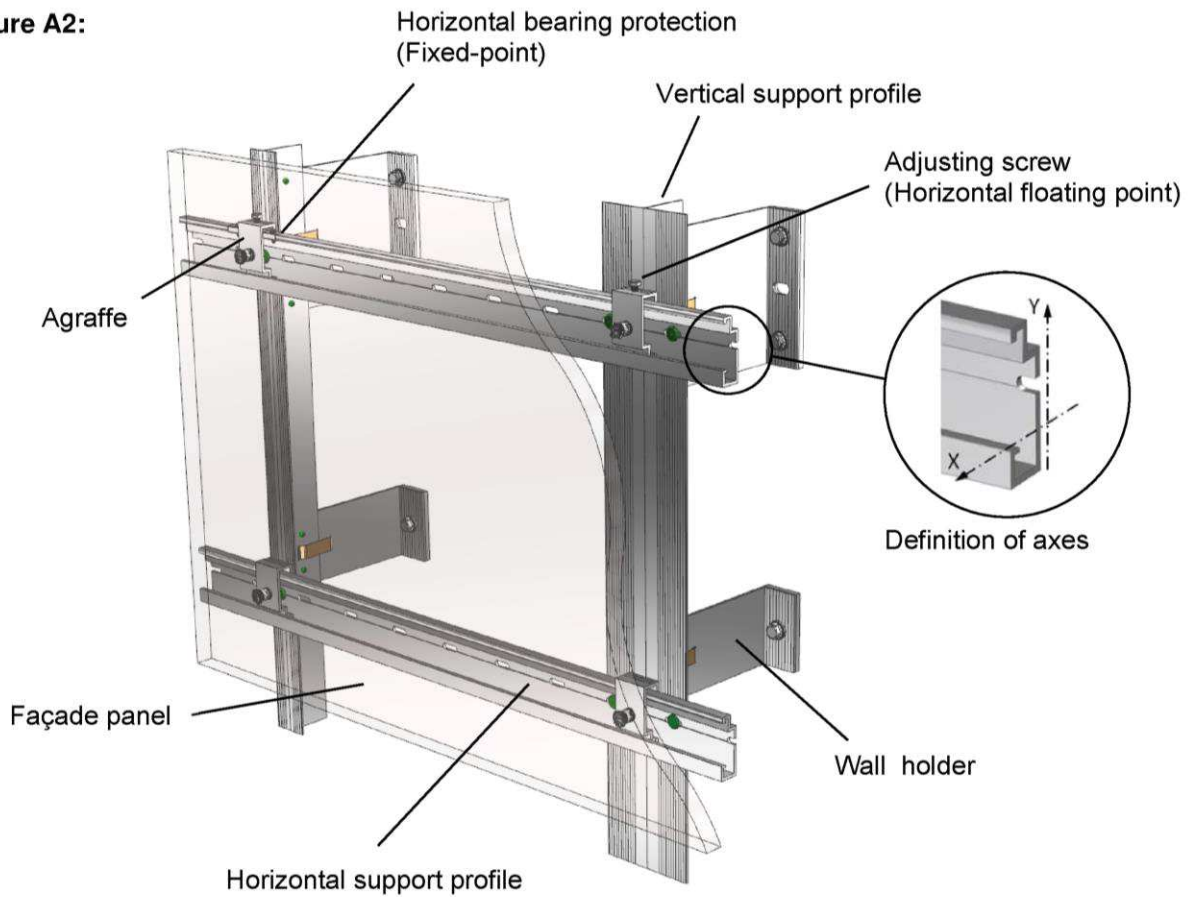

fischer Zykon panel anchor FZP

Product description
Product and built-in state

Annex A 1

Type of anchor

Anchor with external thread

Figure A3:

With carbon fibre sleeve



With steel sleeve



With carbon fibre sleeve and sleeve flange



With Steel sleeve and hex nut SW19



With steel sleeve and hex nut ES ¹⁾



¹⁾ Hex nut ES for suspension systems

Anchor with internal thread

Figure A4:

With carbon fibre sleeve



With steel sleeve



Identification system

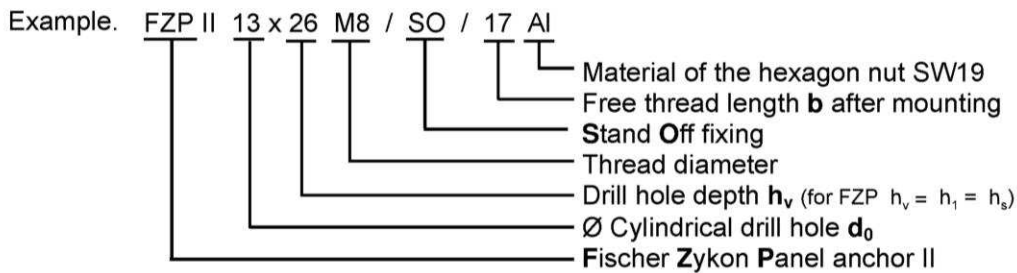

fischer Zykon panel anchor FZP

Product description
Type of anchor and identification system

Annex A 2

Parts of anchor and materials

Cone bolt

Figure A5:

With external thread
M6 / M8 / M10

With internal thread
M6 / M8



Material identification
Option:
Anti rotation lock
Nose or frontal profiling

Option:
Identifying mark, drive, e.g.: Slot;
polygonal (Outside; inside);
spanner flats

Expansion part

Figure A6:



Sleeve

Figure A7:

Carbonfibre

Stainless steel



Type designation e.g.  FZP...

Supplementary components

Figure A8:

Hex nut SW 19

Hex nut ES



Identifying mark of the producer 

Marking: Al = Aluminium
Optional: A4 = stainless steel

Table A1: Material of anchor parts

Anchor parts	Material
Cone bolt	Stainless steel, EN 10088 :2014
Expansion part	Stainless steel, EN 10088 :2014
Sleeve	Stainless steel, EN 10088 :2014
Carbonsleeve	Polyamide 6.6 CF
Hexagonal nut SW19	Aluminium, EN 755 :2016, Stainless steel, EN 10088 :2014
Hexagonal nut ES	Aluminium, EN 755 :2016, Stainless steel, EN 10088 :2014

fischer Zykon panel anchor FZP

Product description
Parts of anchor and material

Annex A 3

Specifications of intended use

Anchorage subject to:

- Static and quasi-static loads.

Anchorage ground:

- Natural stone facade panels according to EN 1469:2015.
- The used material is free of crevices and mechanically effective cracks and alterations.
- Natural stone classified in accordance with Table B1.
- Characteristic values of the panels correspond to Table B2.

Table B1: Stone groups for façade panels made of natural stone

Stone group		Natural stone type	Boundary conditions
I	High quality intrusive rocks (plutonic rocks)	Granite, granitite, tonalite, diorite, monzonite, gabbro, other magmatic plutonic rocks	None
II	Metamorphic rocks with „hard stone characteristics“	Quarzite, granulite, gneiss, migmatite	None
III	High quality extrusive rocks (volcanic rocks)	Basalt and basaltic lava without harmful ingredients (like sun burner basalt)	Minimum density ρ : basalt: 2,7 kg/dm ³ basaltic lava: 2,2 kg/dm ³
IV	Sedimentary rocks with „hard stone characteristics“ ¹⁾	Sandstone, limestone and marble	Sandstone: 2.1 kg/dm ³

¹⁾ For façade panels made of natural stones with planes of anisotropies, the difference between the flexural strength determined parallel to the planes of anisotropy and perpendicular to the edges of the planes of anisotropy shall not be more than 50 %.

Use conditions (Environmental conditions):

- In accordance with EN 1993-1-4:2015 dependent on Corrosion Resistancy Class (CRC) (ETA Section 3.1)

fischer Zykon panel anchor FZP

Intended use
Specifications

Annex B 1

Design:

- The design of anchorages under static and quasistatic load is carried out in accordance with: EOTA Technical Report TR 062 "Design of fasteners for façade panels made of natural stone".
- The façade panels, their fixings as well as the substructure including its connection to wall brackets and their connection to the construction works are designed for the respective case of application under the responsibility of an engineer skilled in the field of façade construction.
- Verifiable calculation notes and drawings shall be prepared taking account of the loads to be anchored, the nature and strength of the base materials and the dimensions of the anchorage members as well as of the relevant tolerances. The position of the anchor is indicated on the design drawings.

Installation:

- The drillings are done at the factory or on site under workshop conditions; when making the drillings on site the execution is supervised by the responsible project supervisor or a skilled representative of the project supervisor.
- Making of the undercut drilling is done with a special drill bit or a special CNC drill bit according to Annex B 4 and a special drilling device in accordance with the information deposited with Deutsches Institut für Bautechnik.
- The drilling residues are removed from the drill hole.
- In case of aborted hole: new drilling at a minimum distance away of twice the depth of the aborted hole.
- The geometry of the drill hole is checked on 1 % of all drillings. The following dimensions shall be checked and documented according to manufacturer's information and testing instructions by means of a control aids according to Annex B 7, Figure B5, B6 and B7.

- Diameter of the cylindrical drill hole.
- Diameter of the undercut.
- Remaining wall thickness (drill hole depth and panel thickness respectively).

- If the tolerance given in Annex B 4, Table B2 is exceeded, the geometry of the drill hole shall be checked on 25 % of the drillings performed. No further drill hole may exceed the tolerances otherwise all the drill holes shall be controlled. Drilling holes falling below or exceeding the tolerances shall be rejected.

Note: Checking the geometry of the drill hole on 1 % of all drillings means that on one of the 25 panels (this corresponds to 100 drillings for panels with 4 undercut anchors) one drilling shall be checked. If the tolerances given in Annex B 4 Table B2 are exceeded the extent of the control shall be increase to 25 % of the drillings, i.e. one drilling each shall be checked on all the 25 panels.

- The anchors are installed in a deformation controlled manner. For this purpose suitable installation tools per Annex B 5, Figure B4 shall be used. The anchor is set correctly if the bolt projection "b" in accordance to Annex A 2 (designation system) according to Annex B 6 Figure B9 and B10 is observed. For flush mounting, the sleeve must not project beyond the plate surface. Internal thread anchors are mounted flush or recessed according to Annex B 6.
- During transport and storage on site the façade panels are protected from damages; the façade panels are not to be hung up jerkily (if need be lifters shall be used for hanging up the façade panels); façade panels and reveal panels respectively with incipient cracks are not be installed.
- The façade panels are arranged in a "reclined" or "upright" position, they also may be fixed at façade soffits.
- The façade are installed by skilled specialists and the laying instructions of the manufacturer shall be paid attention to.
- The façade panels must not be used for the transmission of scheduled impact loads and for the protection against falling.
- Overhead installation is allowed (e.g.: fastening cladding of ceilings)

fischer Zykon panel anchor FZP

Intended use
Specifications

Annex B 2

Table B2: Characteristic values of façade and reveal panels made of nature stones

Façade panels				
Nominal panel thickness	h_{nom}	[mm]	$20 (30)^{1)} \leq h_{nom}$	
Maximum panel size	A	[m ²]	3,0	
Maximum side length	H bzw. L	[m]	3,0	
Number of anchors (rectangular arrangement)	N	[-]	4	
Embedment depth ²⁾	h_s	[mm]	$12 \leq h_s \leq 38$	
Minimum edge distance ³⁾	a_{rL} or a_{rH}	[m]	50	
Maximum edge distance	a_{rL} or a_{rH}	[mm]	0,25 L bzw. 0,25 H	
Minimum spacing ³⁾	a_L or a_H	[mm]	$8 h_s$	
Minimum residual wall thickness ⁴⁾	h_r	[mm]	$0,4 h_{nom}$	
Minimum characteristic flexural strength in accordance with EN 12372				
Padang Cristallo G603, China	Stone group I	$\sigma_{5\%} \geq$	[N/mm ²]	13,4
Jura Limestone (yellow), Germany	Stone group IV	$\sigma_{5\%} \geq$	[N/mm ²]	12,4

- 1) For sandstone, limestone and basaltlava: panel thickness $h \geq 30$ mm, if the bending strength of the material $\sigma_{5\%} < 8$ N/mm².
- 2) $h_s = (h_1) = (h_v)$ in 1 mm steps only (12, 13, 14 mm ... 38 mm) - tolerances see Annex B 4, Table B3, footnote ³⁾
- 3) For small fitting, differential or fill in pieces, the minimum edge distance or spacing shall be chosen constructively. In case of design under static loading using FEM, smaller edge distances are allowed.
- 4) Only for stand-off fixing.

Figure B1: Definition of edge and centre distance

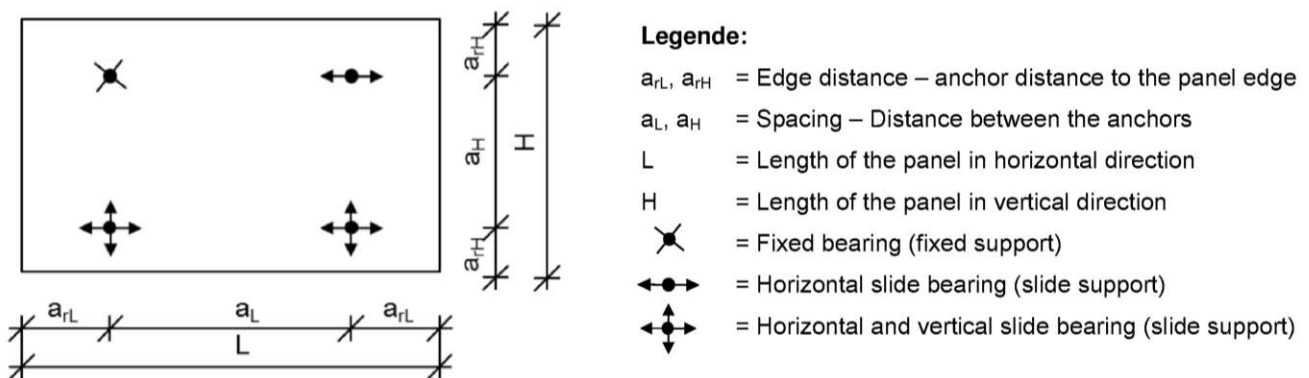

fischer Zykon panel anchor FZP

Intended use
Requirements of façade panels

Annex B 3

Table B3: Drill hole dimensions

Drill hole						
Drill bit $\varnothing f$ ¹⁾	$\varnothing d_0$ [mm] ²⁾	$\varnothing d_1$ [mm] ²⁾	FZPII	n	h_1 [mm] ^{2) 3)}	h_r [mm] ⁴⁾
FZPB 9	11 +0,4 -0,2	13,5 ±0,3	M6	≈ 4	12 ≤ h_1 ≤ 38	≥ 0,4 h
FZPB 11						
FZPB 11	13 +0,4 -0,2	15,5 ±0,3	M8 / M6i			
FZPB 13						
FZPB 13	15 +0,4 -0,2	17,5 ±0,3	M10 / M8i			
FZPB 15						

1) Drill bits for various drilling methods.

2) Dimensions can be checked with the appropriate control equipment in accordance with (Annex B 5).

3) Tolerances flush mounting: $h_1 = h_v$ ^{+0,4}_{-0,1}

4) Only for stand off fixing.

Figure B2: Drill bit example



Figure B3: Geometrie of drill hole

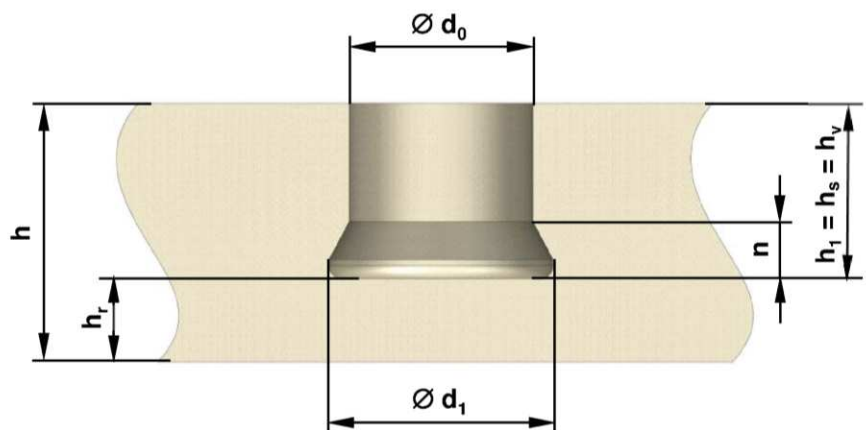

fischer Zykon panel anchor FZP

Intended use

Drill bit, geometry of the drill hole and installation parameters

Annex B 4

Setting tools

Figure B4:



Means for undercut control $\varnothing d_1$

Figure B5:

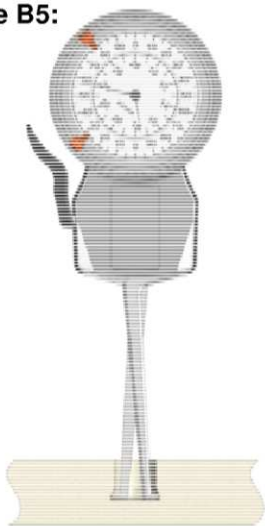

Internal quicktest

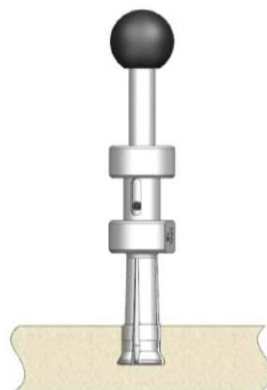

HVL (Undercut minimum volume gauge)

Go / no Go gauge for checking cylindrical drill hole diameter $\varnothing d_0$

Figure B6:

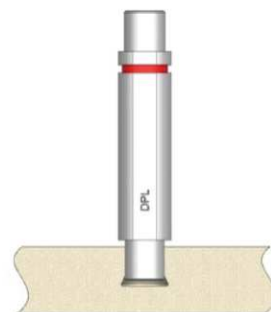

DPL (Diameter gauge)

Means for measuring borehole depth h_1 and borehole diameter h_0

Figure B7:

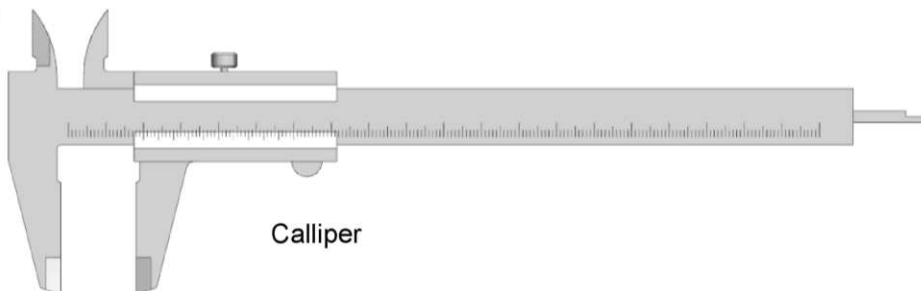

Calliper

fischer Zykon panel anchor FZP

Intended use
Setting devices and testing equipment

Annex B 5

Type of mounting and dimensional definition

Recessed fixing

Figure B8:

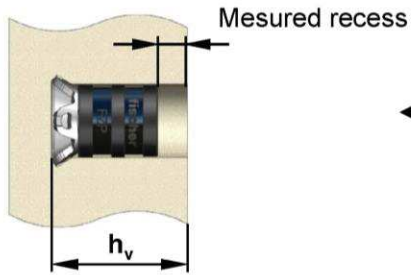

Examples of an adaptation for stand off fixing

Figure B9:

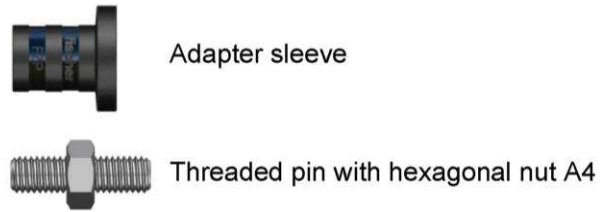

Flush fixing

Figure B10:

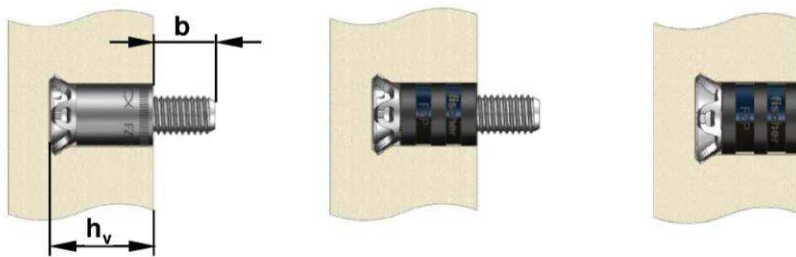

Stand off fixing

Figure B11:

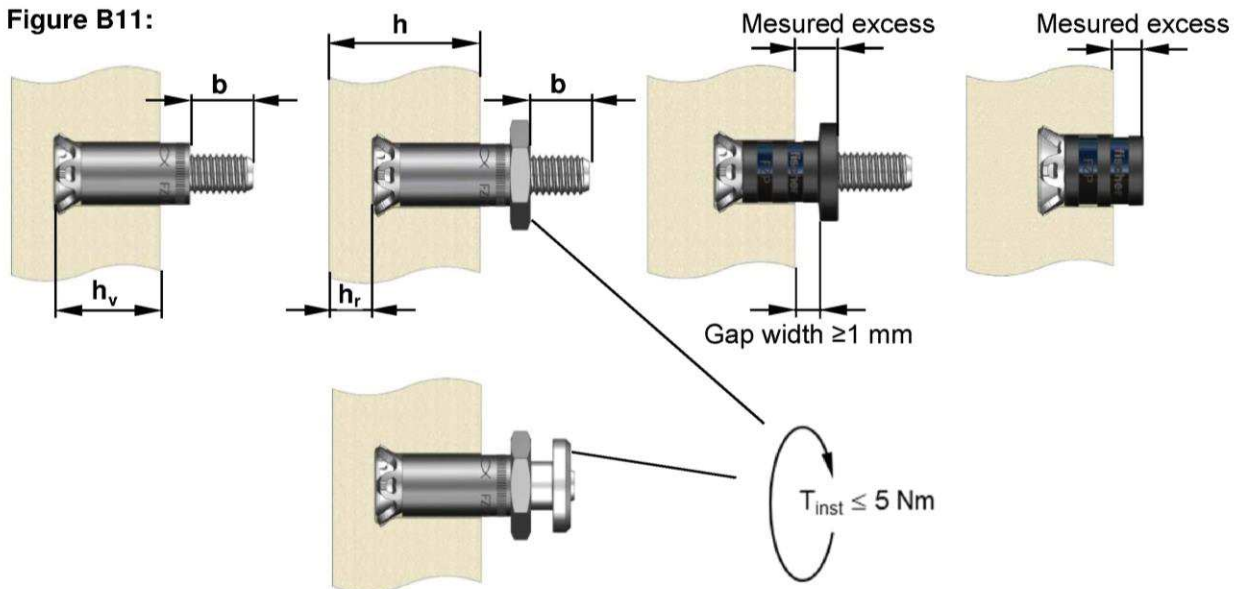

fischer Zykon panel anchor FZP

Intended use
Mounting types and dimension definitions

Annex B 6

Installation instructions

Example: Set with SGA

1.)



2.)

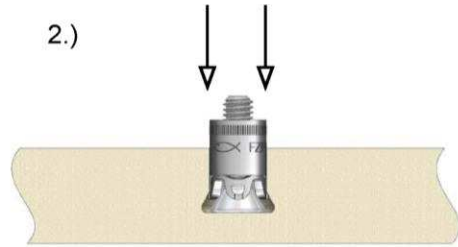

3.)

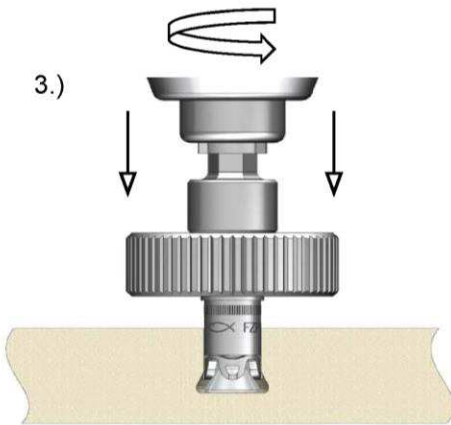

4.)

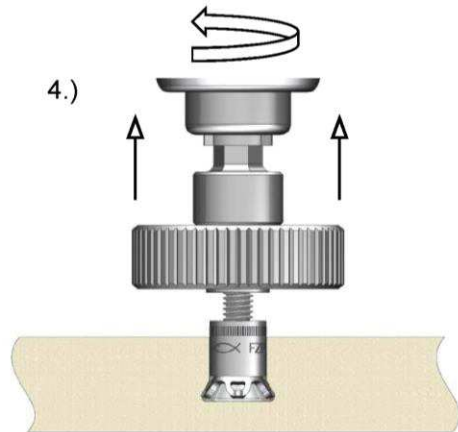

5.1)

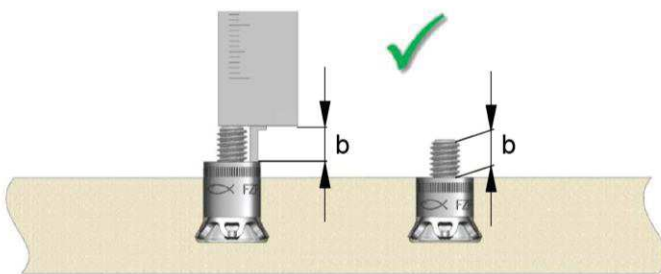

5.2)

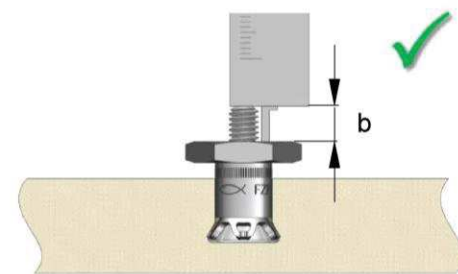

fischer Zykon panel anchor FZP

Intended use
Installation instructions

Annex B 7

Table C1: Characteristic resistance

Diameter of drill hole	$\varnothing d_0$	[mm]	11 (FZP M6)		13 (FZP M8 / M6i)	
Designation of natural stone			Padang Cristallo G603	Jura Limestone (yellow)	Padang Cristallo G603	Jura Limestone (yellow)
Country of origin			China	Germany	China	Germany
Petrographic description			Granite	Limestone	Granite	Limestone
Panel thickness	h	[mm]	30	40	30	40
Edge distance	a_r	[mm]	100	100	100	100
Embedment depth	h_s	[mm]	15	17	17	25
Characteristic resistance						
Tension load	$N_{Rk}^{1)2)}$	[kN]	6,2	4,8	7,8	8,0
Shear load	$V_{Rk}^{1)2)}$	[kN]	7,8	7,9	7,0	9,1
Partial safety factor	γ_M	[-]	1,8			
Combined tension and shear load						
Trilinear limit value	X	[-]	1,2			

- 1) Reduction factor α based on stone class is already included in these values. Reduction factor α in accordance with Technical Report 062 "Design of fasteners for façade panels made of natural stone".
- 2) For other natural stones according to Table B1, the resistance is determined in accordance with EAD 33-0030-0601 and Technical Report "Design of fasteners for façade panels made of natural stone".

Table C2: Characteristic resistance for steel failure

Diameter of drill hole and Anchor	$\varnothing d_0$	[mm]	11	13	15	13 ²⁾	15 ²⁾
			FZP M6	FZP M8	FZP M10	FZP M6i	FZP M8i
Characteristic resistance under tension load	$N_{Rk,s}$	[kN]	15,1	27,5		14,1	
Partial safety factor	$\gamma_{Ms}^{1)}$	[-]	1,5		1,87		
Characteristic resistance under shear load	$V_{Rk,s}$	[kN]	7,5	13,7		7,0	
Partial safety factor	$\gamma_{Ms}^{1)}$	[-]	1,25		1,56		

- 1) In absence of national regulations
- 2) For the anchor with internal thread only a fixing screw of size M6 or M8 made of stainless steel 1.4401 or 1.4571 EN ISO 10088-3 with a minimum strength class 70 according to EN ISO 3506-1 (fuk = 700 N/mm², fyk = 450 N/mm²) can be used

fischer Zykon panel anchor FZP

Performances
Characteristic resistance in natural stone and steel resistance

Annex C 1